

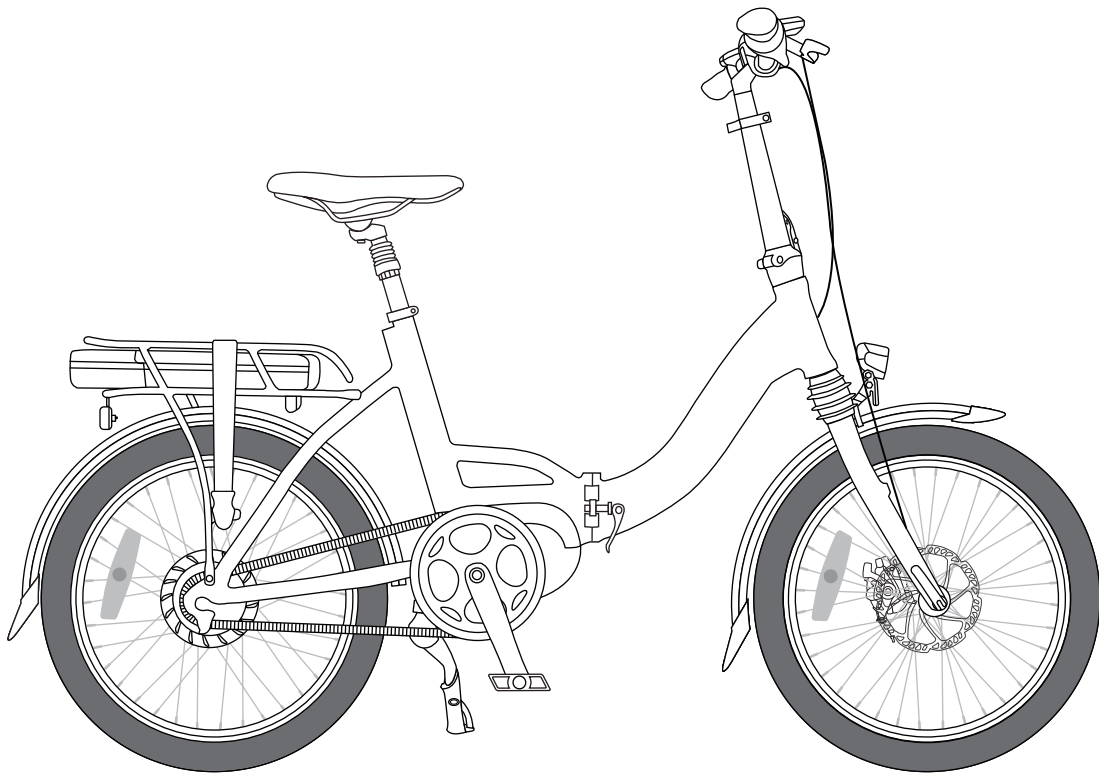

PARIS MAX ^{36V}

USER'S MANUAL



Important information included - please read before your first ride!

1. GENERAL INTRODUCTION

1.1 Welcome	01
1.2 Use of the Manual	01
1.3 Service and Technical Support	01
1.4 Choosing the correct size	01
1.5 Bicycle components	02
1.6 Scope	03
1.7 Recommendations for changes	03

2. SECURITY

2.1 Battery and charger	04
2.2 Use of the bicycle	04
2.3 Transportation	06
2.4 Keys	06

3. INSTALLATION AND ADJUSTMENT

3.1 Handlebar and seat post assembly	07
3.2 Assembling the pedals	07
3.3 To display the table	08
3.4 Seat position	09
3.5 Saddle height	10
3.6 Saddle adjustment	10
3.7 Brakes	10
3.8 Gear shift and gear change adjustment	13

4. GENERAL OVERVIEW OF THE ELECTRONIC PARTS

4.1 Explanation	14
4.2 Battery and charger	14
4.2.1 Overview	14
4.2.2 General remarks	15
4.2.3 Installing and removing the battery	15
4.2.4 Loading	15
4.2.5 Use	16
4.2.6 Storage	17

5. DISPLAY 18**6. RECOMMENDATIONS AND MAINTENANCE**

6.1 General requirements	29
6.2 Maintenance schedule	29
6.3 Troubleshooting	31
6.4 Definition of handling and recommendations	32

7. TECHNICAL DATA 33**8. WARRANTY** 33

1. GENERAL

1.1 Welcome

We would like to thank you for your purchase of an NCM electric bike and welcome our enthusiasm

The growing family of electric bikes. The bikes offer unmatched convenience and excitement, and our electric bikes at NCM are upgraded versions of this incredible invention. As bicycles have evolved, so have we, being at the forefront of innovation in electric cycling technology, aiming to deliver something new and exciting while maintaining and promoting the soul of cycling.

1.2 Use of the Manual

We recommend that you read this manual thoroughly before taking your NCM electric bike for a ride. It is important not to overlook the safety instructions and explanations of traditional and non-traditional bicycle parts as this will give you a general understanding of your new NCM electric bicycle. This manual is designed to help you get the most out of your electric bike, so we have tried to answer as many of your possible questions as possible. Take a moment to read through the different sections before getting in the saddle.

1.3 Service and Technical Support

This manual is intended to be a general description of your new NCM electric bike and is therefore not a reference.

extensive company. For technical assistance, including information on service, maintenance, and repairs, consult your dealer. You can visit our website (www.ncmbikes.com) to learn more about our products and technology, or to find a dealer near you. You can also email your inquiries to us at support.au@leoncycle.com

1.4 Choose the correct size

An important consideration when selecting the size of your new bike is frame clearance - that is, the distance between you and the top tube of the bike when you stand on it with your feet on the ground. For most bikes, this distance should be at least 1 "(25mm). If you choose a mountain bike, it is recommended to have at least 2" (50mm) of clearance. Your dealer can help you find a bike with the correct dimensions for you.

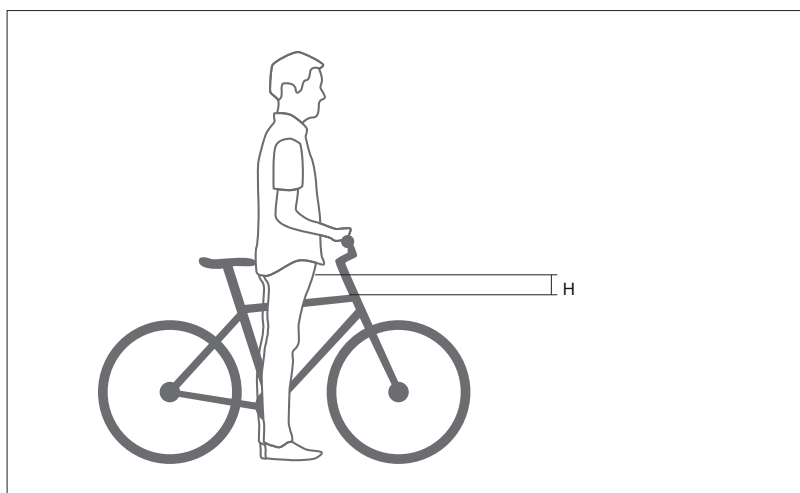

Figure 1
 H = spacing on the frame
 Minimum: 1 "for most bikes
 2 "for mountain bikes

On some bikes, such as low-entry touring bikes, the frame clearance measurement cannot be used as these do not have a top tube or are steeply downward. On these bikes the height of the seat tube will be used to select the correct size. You should be able to comfortably touch the ground while sitting on the saddle when it is at its lowest point on the saddle tube.

Adjusting the saddle can also improve the comfort, fit, and performance of your bike.

The load limit for your bike is 125 kg (including the rider). Some parts have their own load limits, like the rear rack; Please consult your dealer if you are unsure of the load limits for bicycle parts.

1.5 Bicycle components

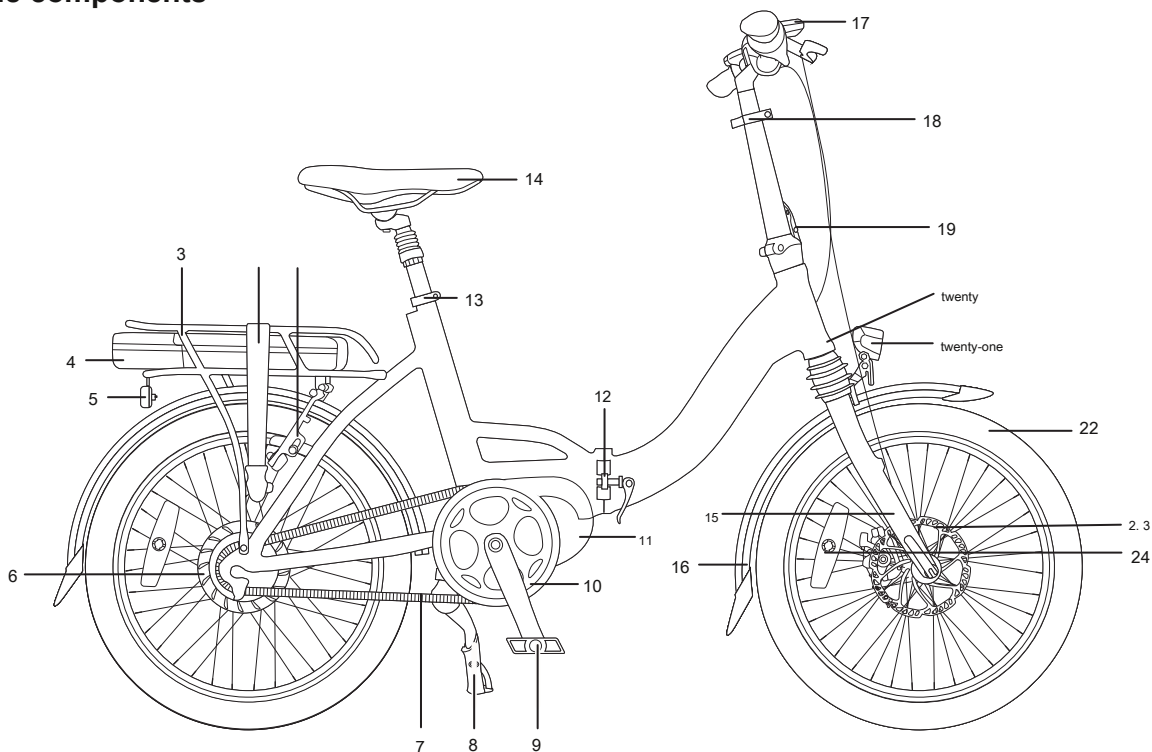

- | | |
|--------------------------------|--|
| 1 Rear V-brake | 13 Quick release saddle |
| 2 Shock cable | 14 Pedal |
| 3 Luggage rack | |
| 4 Battery | 15 Front fork |
| 5 Rear reflector | 16 Mudguards |
| 6 Vespa brake | 17 Display |
| 7 Chain | 18 Quick release of the seatpost |
| 8 Kickstand | 19 Lever to fold the seatpost |
| 9 Pedal | 20 Frame number |
| 10 Connecting rod | 21 Front light |
| 11 Engine | 22 Rims |
| 12 Lever for folding the frame | 23 Front disc brake |
| | 24 Wheel reflector |
| | (different countries use different reflectors) |

Handlebar Accessories

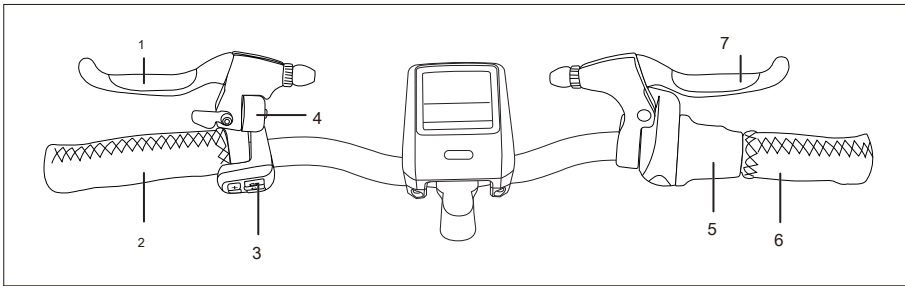

- 1 Left brake lever 2 Left grip
- 3 Display
- 4 Buzzer
- 5 Revo 7-speed gearbox 6 Right grip
- 7 Right brake lever

Frame number indicator

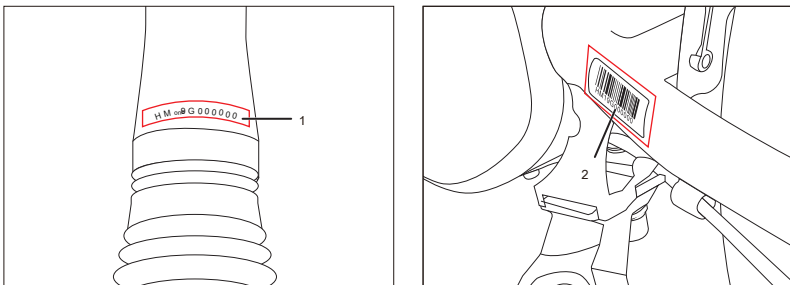

- 1 Frame number (main tube)
- 2 Frame number (sticker)

1.6 Scope

The range on a battery charge is highly dependent on several conditions, such as (but not limited to):

- Road conditions, such as road surface and grade.
- Weather conditions, such as temperature and wind.
- Bicycle conditions, such as tire pressure and maintenance level.
- Use of the bicycle, such as acceleration, shifting and level of engine assistance.
- Weight of the rider and the load.
- Number of charge and discharge cycles.

1.7 Recommendations for changes

For improved range, we recommend shifting according to speed. For getting out and traveling at low speeds, a lower gear is best. At higher speeds a higher gear should be chosen. Releasing the pressure from the pedals during shifting will allow for smooth assistance and better reach.

- High speed, high gear
- Low speed, low gear
- Reduce pedal pressure when shifting

2. SECURITY

2.1 Battery and charger

- Keep the battery and charger away from water and heat sources.
- Do not connect the positive and negative terminals.
- Keep the battery away from children and pets.
- Use the battery and charger only for their intended purpose as part of your e-bike.
- Do not cover the battery or charger, or place objects on it or lean objects against it.
- Do not subject the battery and charger to shocks (eg, dropping).
- Stop charging immediately if you notice anything unusual.

In the unlikely event that the battery catches fire, DO NOT attempt to extinguish it with water. Use sand or other fire retardant instead and call emergency services immediately.

Avoid contact with the battery and charger during the charging process; the charger heats up considerably.



Please note the additional information on the back of the battery box.

2.2 Use of the bicycle

Try all the bike settings and get used to their different results in a safe and controlled environment before attempting to ride the bike on the road. Pedal stand bikes may work differently depending on the configuration used.

IMPORTANT SAFETY INFORMATION

1. Always wear a helmet while driving. Make sure your helmet complies with local laws.
2. Keep body parts and other objects away from moving parts of the bicycle that could cause damage, such as wheels and chain. Do not put any object on the battery or motor. Do not interfere with the transmission in any way.
3. Always wear shoes that will stay on your feet and hold the pedals securely. Never go barefoot or wear sandals.
4. Become familiar with the controls on your bike.
5. Wear bright, conspicuous clothing that is not so loose that you can accidentally get caught in moving parts of the bike or caught by objects on the side of the road or path.
6. Don't jump on your bike. Jumping with a bike puts incredible stress on most components, such as the spokes and pedals. One of the most vulnerable parts to jump-related damage is your front fork. Cyclists who insist on jumping on a bicycle risk causing serious damage to the bicycle and themselves.
7. Consider your speed and keep it at a level that is consistent with the conditions. Always keep in mind that there is a direct relationship between speed and control, and also between speed and component stress.
8. Always follow local traffic laws.
9. Never drive under the influence of alcohol or drugs.
10. If you have any health conditions, consult your doctor before riding your bicycle.
11. Never put yourself or others in danger as a result of reckless driving.
12. Be aware that stopping distance increases with imperfect road conditions such as gravel or wet surfaces.
13. Check the brake cable routing before riding your bike. Make sure both brakes are working and in good condition.
14. The e-bike is especially suitable for riding on trails and paved roads. It is recommended not to use the e-bike for extreme mountain rides with multiple slopes, as the system is not designed for these slopes due to the torque of the engine.

It is common for countries with right-hand traffic to have the front brake on the left brake lever and the rear brake on the right lever. The opposite is generally possible in countries with left-hand traffic. The table below shows several examples.

country	Cable routing	country	Cable routing
Austria	The left lever controls the front brake, The right lever controls the rear brake,	Australia	The left lever controls the rear brake, The right lever controls the front brake,
Brazil		Indonesia	
Canada		Japan	
Denmark		Hongkong	
France		Malaysia	
Germany		New Zealand	
Italy		Singapore	
Netherlands		United Kingdom	
Portugal			
Poland			
Spain			
South Korea			
Switzerland			
Russia			
United States			

⚠ WARNING:

- Drive within the age limits established in your country.
- Do not touch hot surfaces after heavy use, such as the disc brake rotor or the side edge of the V-brake edge.
- When unfolding the kickstand, always make sure that the stand is secure and that the base is solid so that the bike does not fall over.
- Drive within the age limits established in your country.
- Turn the key to the "OFF" position (turn off the power), then remove the key if you stop using the electric bike.

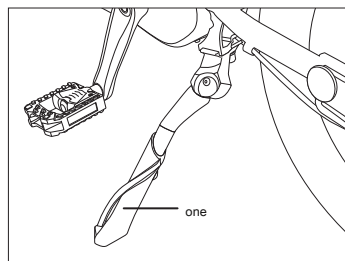

Inflate the tires

⚠ WARNING:

You should always check your tire pressure before you start driving, or at least once a week. Check the sidewall of the tire for the minimum and maximum inflation pressures, and always make sure your wheels are inflated to a pressure within the stated range. If the pressure is too low, the wheel could be damaged or the inner tube could be pinched, resulting in a flat tire. If the pressure exceeds the maximum recommended amount, the tire can come off the rim, damaging the bike and injuring the rider and those nearby.

To ensure that you always have the correct and desirable pressure in your tires, use a bicycle pump with a built-in pressure gauge.

2.3 Transportation

Transport by car

Batteries should be removed from the bicycle during transport by car, as they can be damaged by excessive and repeated shocks or by foreign objects striking the bicycle at high speed.

Please remove the batteries and keep them inside the vehicle during transportation.

Remove the front wheel for transportation

- Open the quick release lever (1) and loosen the axle nut (2) a couple of turns.
- Remove the front wheel (3) from the fork downwards.

Install the front wheel

- Insert the front wheel (3) into the outlets (4) of the fork.
- Tighten the axle nut (2) and close the quick release lever (1).
- The lever must point upwards (and aligned with the fork to avoid them snagging) and must be closed with considerable pressure.

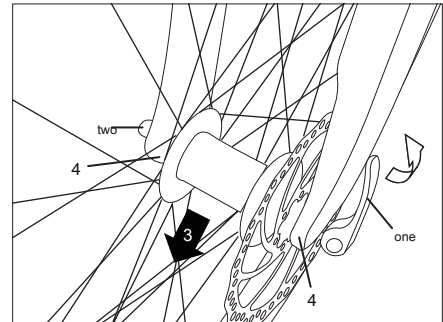

WARNING:

- To avoid any danger, after installing the wheel, check the brake system before riding the bicycle.
- If the quick release lever has not been fully closed, it can be fully opened again easily. This can cause the wheel to come off the bike, causing a serious fall or damage to the bike. To ensure your wheel is properly in place, the quick release lever must offer considerable resistance when closed manually and should always be fully closed before riding the bike.

2.4 Keys

Each NCM electric bike comes with two copies of the battery fixing key. Bicycles with ring locks come with additional keys (not the same key as the battery). On-board charging of the battery will likely lead to infrequent use of the battery fixing key; it is required for maintenance and repair, however, keep this in mind when storing the key.

- Make sure you always have at least one spare key.
- Keep spare keys in a safe place for repair, maintenance, and emergencies.
- Please bring the key with you when you go to your NCM dealer for maintenance or repairs.

3. INSTALLATION AND ADJUSTMENT

3.1 Handlebar and seat post assembly

Lift the handlebar and plastic cover into place, then press the lock lever to secure the stem.

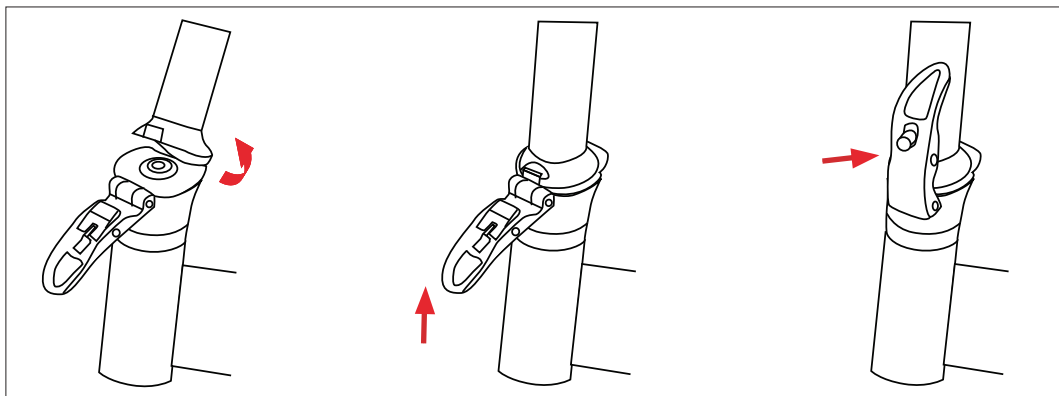

3.2 Mounting the pedals

- Identify your pedals: check the letters on the pedal, "L" or "R".
- The pedal marked "R" is the one on the right (looking straight ahead in the direction of travel). To attach it to the crank, tighten it clockwise.
- The pedal marked "L" is for the left. To join, tighten it counterclockwise when looking directly.

⚠ WARNING:

First screw in the pedals by hand, then tighten them with the tool.

If the pedal is folded, simply pull it parallel to the pedal deck and it will snap into place.

To bend the pedal, push the outer part towards the crank and then down to a perpendicular position to the pedal deck.

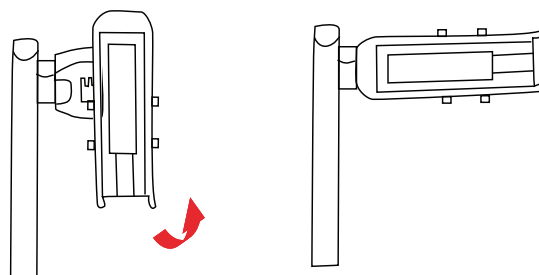

3.3 To display the table

Align the two parts of the frame, pull the lever (2) down, and then close the small lock lever (2) down to lock the frame. Lever (2) needs additional force to fully close.

To fold the box

Pull the small lock lever (1) up and then open the lever (2), then the bike will be unlocked and can be folded for storage or transport.

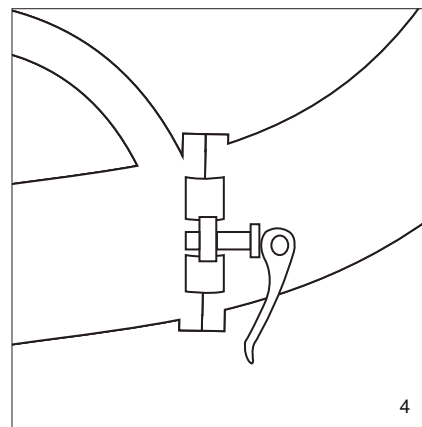
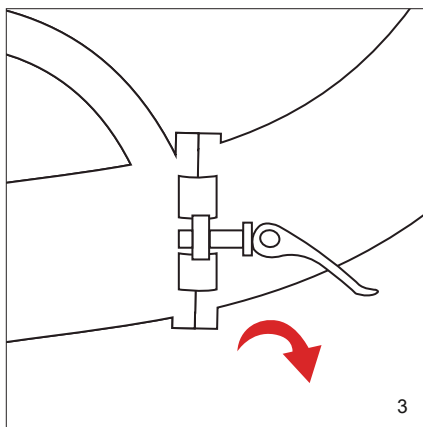
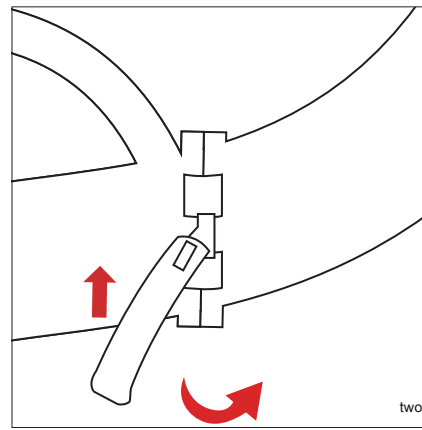
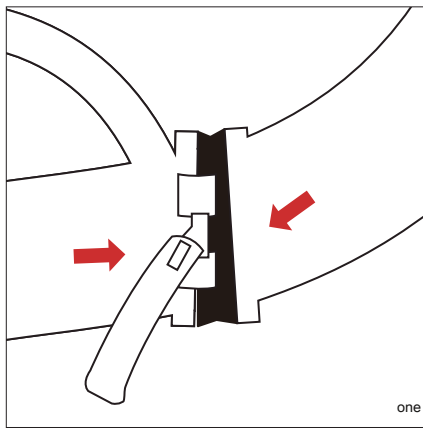

3.4 Seat position

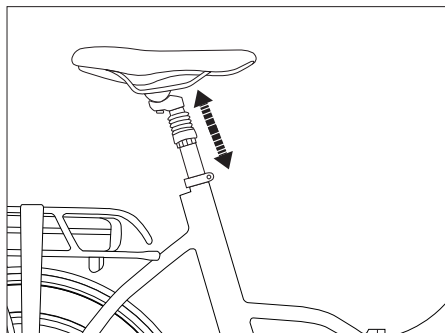

To allow a comfortable, fatigue-free and safe ride, the height of the saddle and handlebar must be adjusted to the user's body size.

The saddle height is correct if the leg is close to full extension while the foot is resting on the pedal in the lower position of the start cycle. The toes should still be able to touch the ground comfortably.

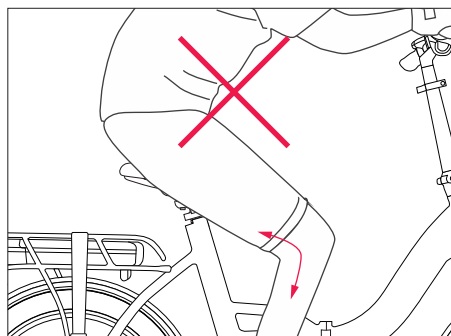

Very low

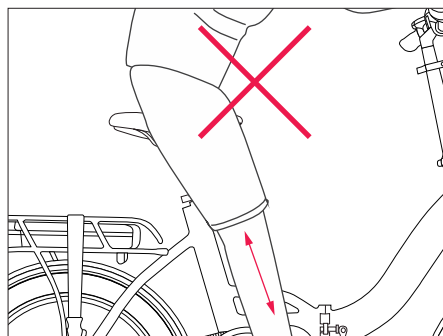

Very high

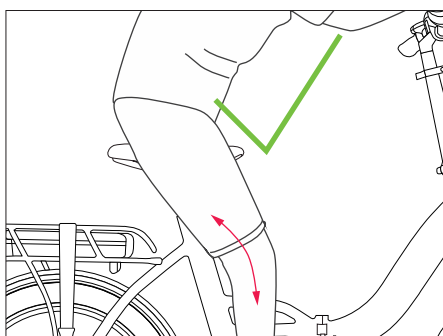

Optimum

3.5 Saddle height

The quick release lever should require considerable effort to bring it to the fully closed position to prevent any unwanted movement while driving.

WARNING:

A poorly closed quick-release lever may reopen or have limited ability to hold the saddle in place. This can cause the saddle to suddenly drop onto the seat tube, which can lead to falls and serious injury.

There is a minimum insertion line marked on the seat tube (failure to adhere to the minimum insertion line can result in serious injury); make sure the seat post is always inserted into the seat tube beyond this line (the line must be inside the seat tube).

- Loosen the quick release lever at the top of the seat tube, determine the proper saddle height and tighten the clamp.

- The clamping force can be adjusted by adjusting the bolt on the quick release lever.

- The quick release lever must be closed with considerable back pressure.

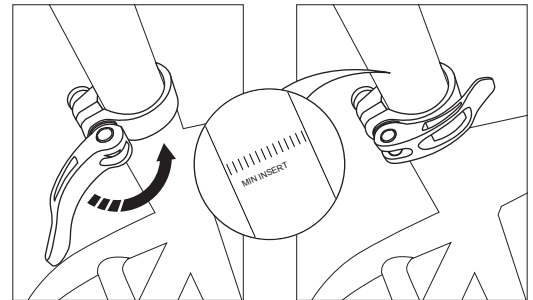

3.6 Saddle adjustment

The saddle can be tilted and adjusted in the forward / backward direction.

- Loosen the bolt at the bottom (4).

- Adjust the incline of the saddle by pressing down on the front or rear of the saddle.

- Move the saddle forwards or backwards to adjust the arm / torso length and the desired riding position. Tighten the bolt (4) to secure the saddle.

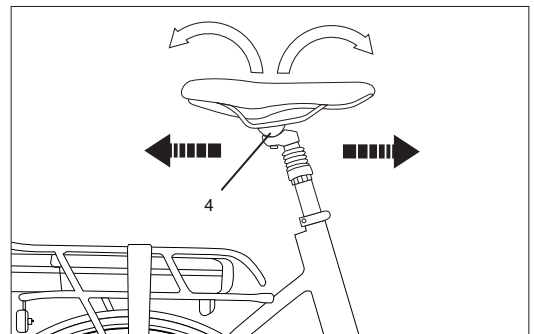

WARNING:

To avoid discomfort, the saddle should generally be placed as horizontal as possible.

3.7 Brakes

3.7.1 General

In most countries, bicycles are made so that the left brake lever controls the front wheel brake; To change this, contact your dealer for assistance, note Section 2 - Important Safety Information.

If your bike has two parking brakes, apply both brakes at the same time for optimal stopping distance.

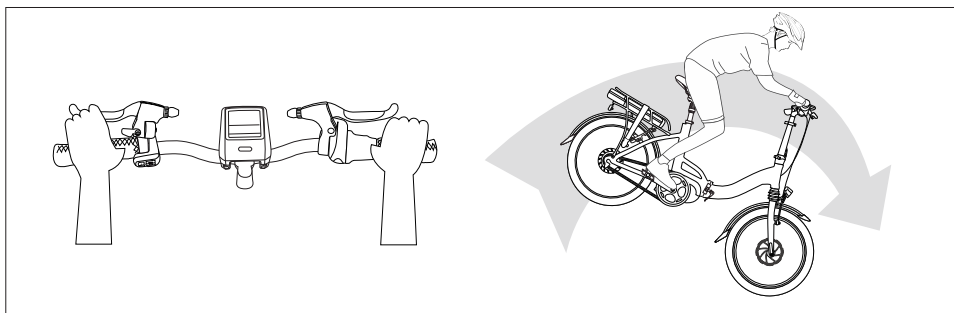

⚠ WARNING:

Overuse or improper use of the front wheel brake can cause the rear wheel to lift off the ground, resulting in decreased control of the bike or even the bike toppling over and the rider falling in the direction of the movement; This can cause serious injury and damage to the bike. Be careful when applying the front brake, and avoid using it without also using the rear brake. Ideally, the brakes should be applied at the same time, with the rider moving backwards on the bike, depending on the amount of brake pressure applied.

⚠ WARNING:

The brake pads remove material from the rim when the brake is applied. If the brakes remove too much material over time, the tire can weaken and break, decrease control and cause a fall. Check your tires regularly. Replace a worn tire.

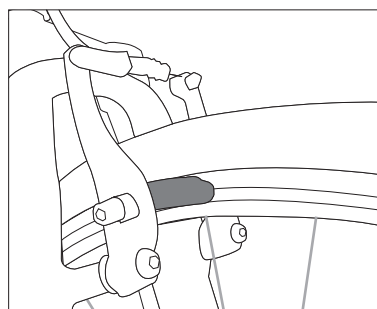

Rim wear indicator: shallow groove in the braking track of the aluminum rim

3.7.2 Brake adjustment Disc brakes

When the wheel is out of the frame, do not operate the brake lever. With some brakes, the pads automatically adjust their clearance so that you won't be able to reinsert the disc.

Alignment of a mechanical disc brake

1. Loosen or tighten the tensioner at the end of the brake cable lever. This will make a small adjustment in the brake shoe clearance. If this is insufficient to create adequate space.
2. Loosen the two alignment bolts but do not remove them. Slowly turn the wheel and check the gap between the rotor and the brake pads; adjust the position of the brake shoes so that the rotor is not rubbing and is slightly closer to the outer pad (the gap between the rotor and the pad should be just enough to avoid chafing). Make sure the rotor and pads are parallel to each other. Tighten the screws when the adjustment is complete.
3. If the rotor is always rubbing against the brake shoes or if there is a lot of gap, the brake pad gap can be adjusted by loosening the cable clamp bolt and loosening the cable slightly to increase the gap or tightening the cable to decrease the gap, then tighten the bolt again.

Note: Make sure the brake cables are properly inserted into the brake levers before adjusting the brakes.

⚠ WARNING:

If the disc rotor is bent or broken, please replace the rotor first.

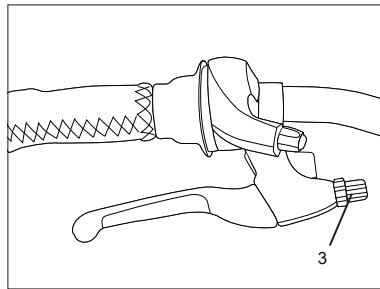
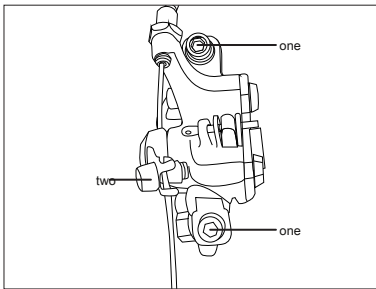

- 1.Alignment bolts
- 2.Cable-bolt clamp
- 3.adjuster-pads

Rim brake (V-brake)

Brake modulator

Brakes have a brake modulator, or "power modulator." This device includes a small spring in the brake tube. As the brake lever is squeezed, you must compress the spring before you can apply full stopping power to the rim.

This changes the way the brake feels, makes the application of braking force more gradual, and also makes the adjustment somewhat more responsive.

To adjust the alignment of the brake pads on a rim brake

1. Loosen the brake pad fixing bolt.
2. Align the brake pads as shown in the figure above. Tighten the brake pad fixing bolts.
3. After adjusting the brake, test it by pulling the lever. Make sure that the cable does not slip through the cable clamp, the brake pads mesh with the rim at ninety degree angles, and the brake pads do not touch the rim.

To adjust the gap between the brake pads and the rim

1. Turn the pad adjuster located on the brake lever.

- To increase the clearance between the brake pads and the rim, turn the pad adjuster clockwise.
- To decrease the gap, turn the pad adjuster counter-clockwise.

2. If the brake pads cannot be adjusted correctly with the pad adjuster, then additional work is required:

- Loosen the bolt on the cable clamp, tighten the cable and tighten the bolt again.
- Release the cable slightly to increase the gap.
- Tighten the cable to reduce the gap.
- Readjust the brake pad alignment or take the bike to your dealer.

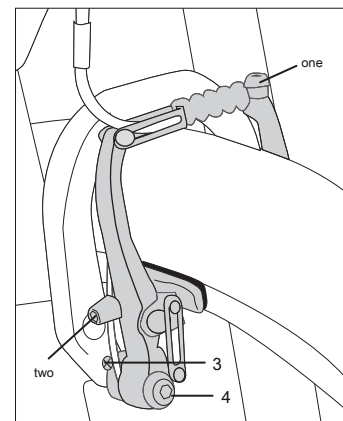

- 1.Cable-bolt clamp
- 2.Pad-bolt clamp
- 3.Center-adjusting screw
- 4.Arm-bolt clamp

Hub brakes

A hub brake, like a coaster brake, typically requires multiple frame accessories and multiple adjustments. Due to this complexity and the importance of properly adjusting the brake for your safety, we strongly recommend that only your dealer or manufacturer make any adjustments to a hub brake or removal of the wheel from the frame.

3.8 Shift adjustment and speed change

Internal rear derailleur adjustment (Nexus 8-speed)

These systems change gears with a mechanism located on the rear hub. Check the internal gear system monthly.

1. Rotate the shift lever to fourth gear.
2. Check the rear hub pulley indicator with the toothed joint bracket. If the red lines are not aligned, turn the pad adjuster until they are aligned.
3. Put the gear lever in first gear. Then move the lever to fourth gear. Check the setting.

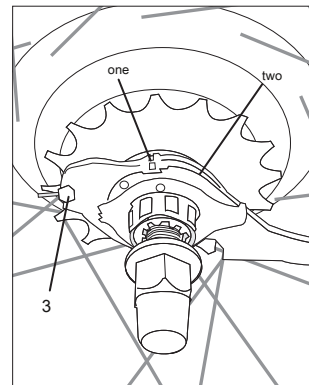

1. Pulley
2. Toothed joint support
3. Cable clamp bolt

4. GENERAL OVERVIEW OF THE ELECTRONIC PARTS

4.1 Explanation

NCM electric bikes are equipped with components that work together to give you a smooth, powerful and effortless riding feel. Our pedaling assistance system consists of the following:

Drums

The lithium ion battery packs for NCM electric bikes are some of the highest capacity packs available on the market, with NCM Milano MAX storing up to 504Wh of energy. The packs consist of high-density Panasonic cells, which means our designs stay sleek and lightweight without sacrificing battery capacity. Additionally, most of our designs have a built-in USB port, perfect for charging your cell phone or other small electronic devices on the go.

BAFANG powered motor

With a reliable, compact but powerful 250W BAFANG motor, you will always have the required assistance on hand when you need it. Offering a smooth and quiet ride at all levels of assistance, this engine is perfect for helping the rider navigate crowded city streets, as well as peaceful parks and natural areas.

screen

The BAFANG control panel provides the rider with complete control over the electrical system, and its simple setup provides all the information they might need about their e-bike at the push of a button, allowing them to spend more time enjoying the world around them. The screen provides the following information:

- Battery level indicator
- Assistance level indicator
- General indicators: speed, distance, etc.

When using the brake with the brake sensor, the sensors inside make the assist immediately stop the engine. Activation of the rear brake will automatically stop the engine assist in all cases. Another sensor, inside the crankset, also serves to stop the engine when the rider stops pedaling.

The bicycle can also be used without electric motor assistance; By setting the assist level to 0, the electric bike will behave like a traditional bike. An empty battery will not make your bike unusable.

4.2 Battery and charger

4.2.1 Overview

- 1 Battery
- 2 Battery lock
- 3 Charging socket
- 4 Capacity level button
- 5 Capacity level light
- 6 battery power button

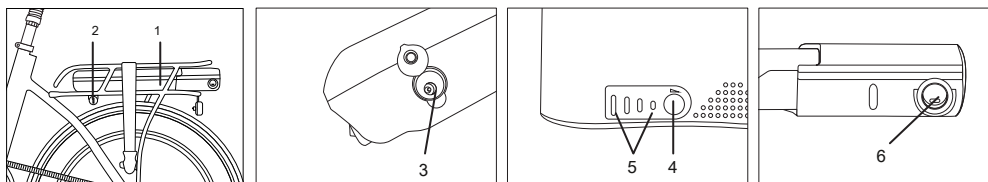

⚠ WARNING: (Sticker on battery)

Make sure the battery is locked before use.

⚠ ATTENTION: (Sticker on battery)

- Do not use or charge the battery in high temperature.
- Do not short-circuit the positive (+) and negative (-) connectors of the battery.
- Do not immerse the battery in water or acidic liquid. Do not place the battery near fire.
- Do not disassemble the battery under any circumstances.
- Store the battery in a clean and dry environment, and charge the battery for two hours every three months when it will not be used for a long time.
- Charge the battery with the specified charger.

An AC plug (100 ~ 240V) (type will vary) B Charger

C Charge indicator D Battery plug

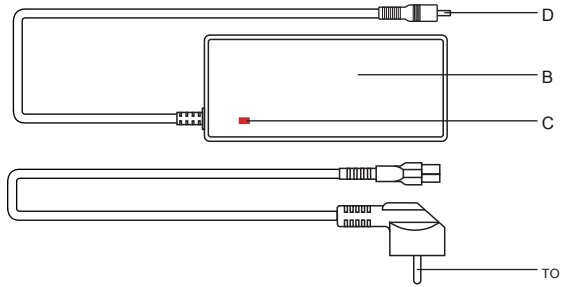

4.2.2 General remarks

- Stop charging the battery immediately if you notice anything unusual, such as smoke or a strange smell, remove the battery and store it outside the house, then take the battery to an authorized NCM dealer or an experienced technician for repair or replacement.
- In the unlikely event that the battery catches fire, DO NOT attempt to extinguish it with water. Use sand or other fire retardant instead and call emergency services immediately.

4.2.3 Battery Installation and Removal

The battery (1) is secured with a lock.

- Unlock the battery and pull it out with the handle (2).
- Insert the battery (1) into the frame until it stops.
- Remove the key from the lock (3).
- Make sure the battery is well secured.

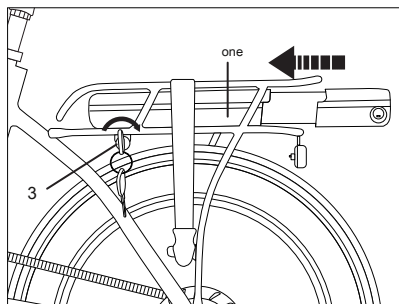
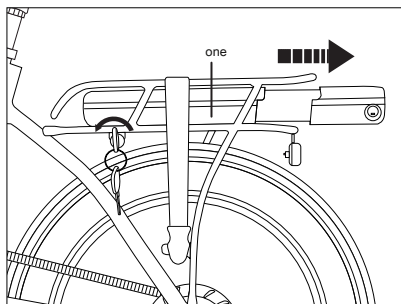

4.2.4 Loading

- Charging in temperatures below 0 ° C or above 60 ° C may cause the battery to not charge properly and may be harmful to battery life.
- During charging, the charger LED light will be continuously red.
- When charging is complete the LED on the charger turns green.

Charging the battery outside the bike

1. Unfold the box first.
2. Take out the battery
3. Connect the charger to the battery.
4. Connect the charger to an AC outlet.
5. The charging procedure can be stopped at any time.
6. Disconnect the charger from the AC outlet first and then from the battery.
7. Reinstall the battery and make sure it is aligned correctly at the bottom.
8. Press down on the top of the battery until you notice a "click" to ensure that the battery is properly secured.

9. Remove the key.
10. Your NCM electric bike is ready to ride.

Charging the battery inside the bike

1. Connect the charger to the battery.
2. Connect the charger to an AC outlet.
3. The charging procedure can be stopped at any time.
4. Disconnect the charger from the AC outlet first and then from the battery.
5. Your NCM electric bike is ready to ride.

4.2.5 Use

Make sure to activate the battery by turning on the power button on the right side of the protector.

Turn on the display on the handlebar, select the desired level of support, and begin pedaling. You will notice that the engine starts as soon as you start moving the pedals.

The charging time will be around 4 hours at a time. Please do not charge the battery for more than 10 hours at a time (the battery will be fully charged much earlier).

A fall resulting in serious injury can occur if the following points are not observed:

1. Before setting off, hold the handlebar straight.

2. To get familiar with the feel of the bike and riding, start with the engine off (you can set the support level to 0 on the monitor) Do not start the engine until it is moving.

3. Do not use the pedals to begin moving until you have assumed a safe and comfortable sitting position.

4. When driving around a sharp curve or corner, apply the brake lightly to temporarily disable the engine and allow a safe turn.

The bike can be operated with and without the motor auxiliary drive bracket. An empty battery does NOT mean that your bike cannot be used again.

When using the motor for pedal assist, proceed as if you were riding a normal bicycle; press down on the pedals and the motor will start and the bike will accelerate further.

Support level

If the bike remains stopped with the display and auxiliary unit activated, it will turn off after approximately 10 minutes along with the battery capacity indicator.

During longer slopes, the engine can get so hot that the current is reduced through the temperature sensor inside, causing the engine support level to drop; the driver may need to increase the physical support of the pedal to maintain speed.

4.2.6 Storage

If the bicycle is not used for more than a month, it is better to store the battery:

- At 40% -60% of its capacity, charged once a month for 30 minutes.
- Separated from the bicycle.
- At temperatures between 0 ° C and 40 ° C.

If not in use, the battery should be checked once a month and should have at least one blinking light, indicating the remaining charge. Charge the battery if necessary.

It is important to charge the battery every three months (for one to two hours) at least. Failure to do so may cause damage to the battery and could void the battery warranty.

5. Display

5.1 Display specifications and parameters

- 36V / 48V power supply;
- Nominal current: 10 mA
- Maximum operating current: 30 mA
- Power off leakage current: <1 uA
- Operating current supplied to the regulator: 50 mA
- Operating temperature: -18 ~ 60%
- Storage temperature: -30 ~ 70%
- Degree of waterproofing: IP65
- Storage humidity: 30% ~70%

the shell is made of PC. the liquid crystal display is made of hardened PMMA.



5.2 Overview of functions and key definitions

5.2.1 Overview of functions

- Use of a bidirectional serial communication protocol, easy operation of the screen through the external 5-key keyboard.
- Speed display: Shows real-time speed as SPEED, maximum speed as MAXS, and average speed as AVG.
- Km or mile: the user can choose between km and mile.
- Intelligent battery charge level indicator: An optimization algorithm ensures a stable display of the battery charge level, avoiding the problem of fluctuating charge level indication common on other displays.
- Automatic light-sensitive lights: The headlight, taillight, and viewing light will turn on and off automatically depending on the lighting conditions.
- 5 levels of backlighting on the screen: different levels.
- 5-level assistance: adjustment of power levels 1 to 5.
- Trip distance indication: maximum distance displayed is 99999. TRIP single trip distances or total total distance can be displayed.
- Display of error messages.
- Assistance in walking.
- Configuration: through a communication cable, different parameters can be adjusted on the computer such as, p. eg, mode, wheel diameter, speed limit, etc. See setting.
- Maintenance Notice (This feature can be disabled): The maintenance notice information is disabled based on battery charge cycles and travel distance. the screen automatically calculates the battery life and issues warnings when the number of charge cycles exceeds the set value. A warning will also be displayed when the total accumulated distance exceeds the set value.

5.2.2 Information on the screen

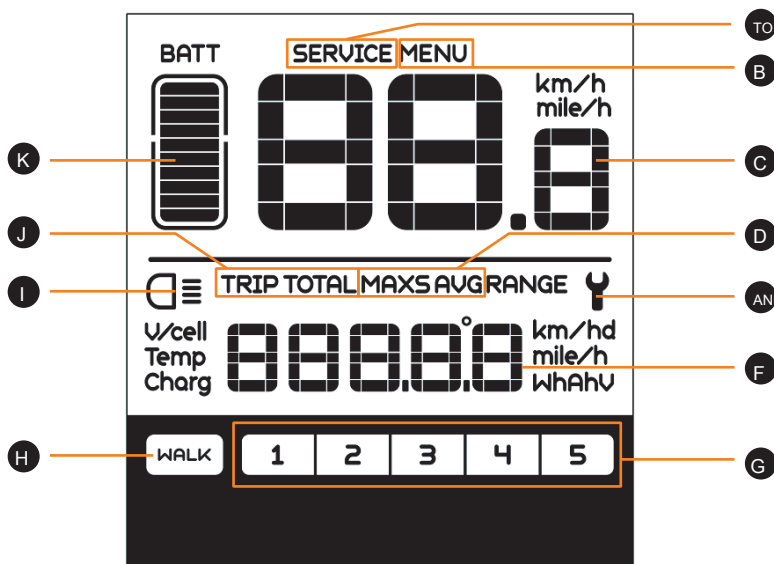

A. Maintenance notice: in case of maintenance, the symbol will be displayed
 number of battery charge cycles exceeds the set value, the function may be disabled).

B. Menu

C. Speed display: speed display, km / h or mph.

D. Speed mode: medium speed (AVG km / h), maximum speed (MAXS km / h). Error display: when a fault is detected,

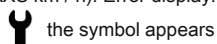

F. Distance indication: distance display depending on the setting.

SERVICE (travel distance or

G. Level indication: the selected level 1-5 will be displayed; if there is no numerical display, it means that there is no assistance (from the engine). If the rider is walking and pushing the electric bike, **WALK** will be shown.

H. Assistance in the march on foot.

I. Headlight Indication - Only displayed when the headlight or backlight is on.

J. Distance mode: display of tRIP single trip distance and total total distance.

K. Battery level: 10-segment battery indication; the voltage that each segment represents can be customized.

5.2.3 Key definitions

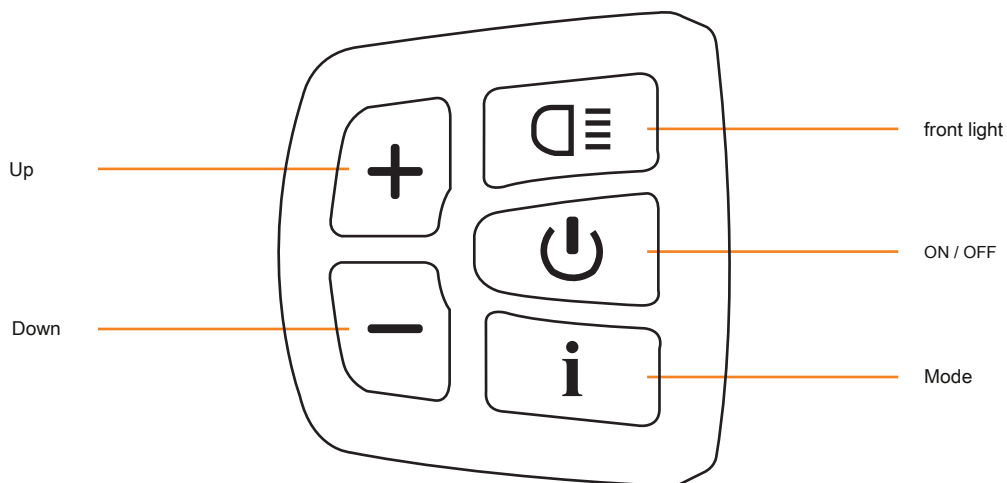

5.3 Normal operation

5.3.1 ON / OFF switch

Turn on the device. Hold down for 2 seconds to turn on the screen. Press and hold again for 2 seconds to turn off the screen. If the bike is not in use, the screen will turn off automatically after 5 minutes (time can be adjusted).

5.3.2 Selecting the assist mode

In manual shift mode, press or to choose the level of assistance desired by the engine. The lowest level is the Level 1 and the highest level is Level 5. When the display is on, the default mode is Level 1. When there is no numeric mode display, there is no power assist.

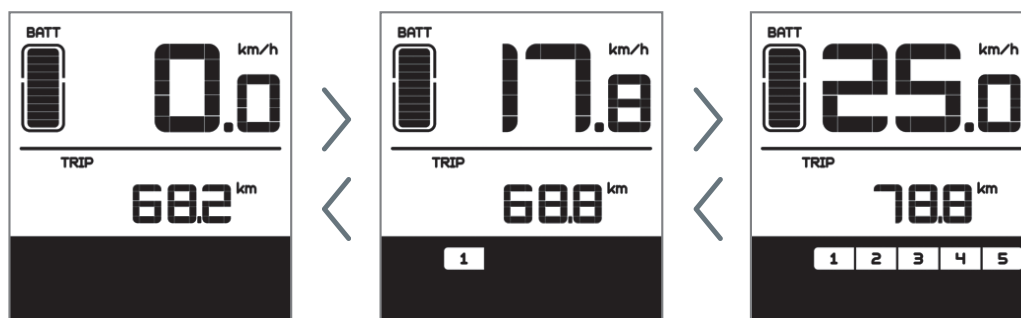

Selecting the level of engine assistance



5.3.3 Switching between distance mode and speed mode

Press briefly  to switch between distance and speed. One-way distance (TRIP km) → the total distance (totAL km), → maximum speed (MAXS km / h) and → Average driving speed (AVG km / h) are displayed in successive order.



Switching between displays

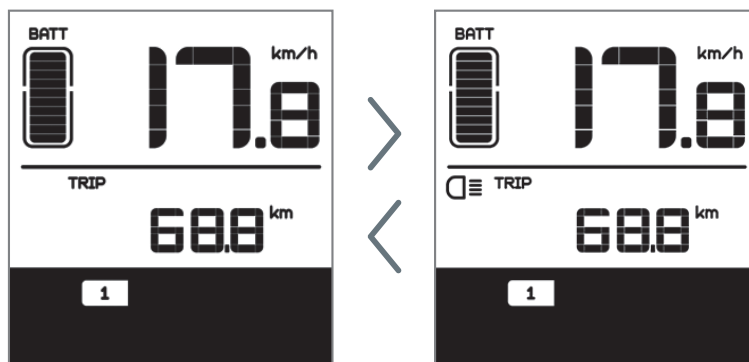

5.3.4 Headlight / Display Backlight Switch

Press  for 2 seconds. The display feedback and the headlight and tail lights will turn on. Press for 2 seconds to turn off the display / headlight / tail new  light feedback. (If the screen is Turn on in dark environment, the feedback / headlight / tail light will automatically turn on. If the feedback / headlight / rear light are turned off manually, they will also need to be turned on manually).



*Display backlight, headlight and rear light
The user can choose between 5 levels of feedback brightness.*

5.3.5 Assistance in walking

Press  for 2 seconds. The e-bike enters walk assistance mode and the symbol appears WALK. When the key is released , the e-bike exits the walk assist mode.

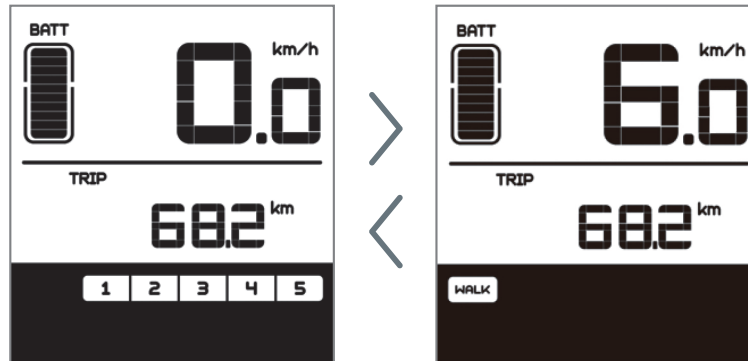

Switching between electric assist mode and mode assistance in walking

The system provides discreet to powerful assistance (depending on the configuration selected) to the driver and also facilitates driving on slopes or against the wind. However, it is assumed that the system has adequate user assistance. If the motor is overloaded, the system automatically shuts down to protect technical components from possible damage.

To avoid this, use the electric bicycle as a non-assisted bicycle on long, steep slopes. Example of a 7 speed gearbox:

On steep slopes, select the maximum assist level 3 and shift to a lower gear, eg 2-3, and offer assistance to the system.

It has 5 levels of assistance 0-5. The following information is approximate and therefore may vary slightly.

- 1 = 7-12 km / h
- 2 = 12-16 km / h
- 3 = 16-19 km / h
- 4 = 19-22 km / h
- 5 = 22-25 km / h

The engine only provides assistance in levels 1-5 up to the specified speed.
All speeds above these values must be assisted by your own muscular strength.

5.3.6 Battery status indication

When the battery status is normal, a certain number of battery LCD display segments and the edge light, depending on the actual amount of charge. If all 10 segments turn off and the edge blinks, the battery should be charged immediately.

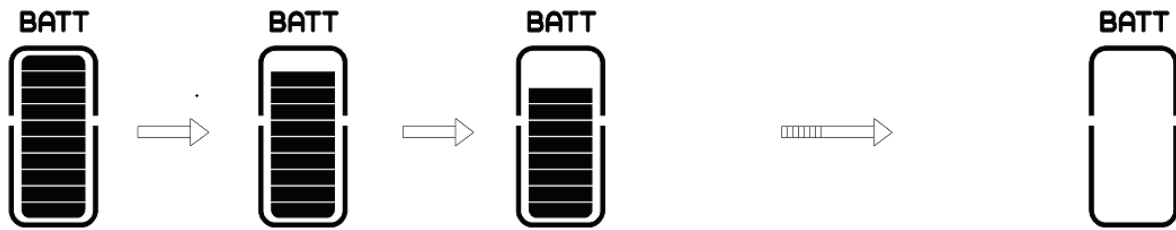

Battery status indication

Battery status indicator correspondence table (C):



Number of segments	Load in percentage	Number of segments	Load in percentage	Number of segments	Load in percentage
10	$\geq 90\%$	6	$50\% \leq C < 60\%$	two	$15\% \leq C < 25\%$
9	$80\% \leq C < 90\%$	5	$45\% \leq C < 50\%$	one	$5\% \leq C < 15\%$
8	$70\% \leq C < 80\%$	4	$35\% \leq C < 45\%$	edge blinking	$C < 5\%$
7	$60\% \leq C < 70\%$	3	$25\% \leq C < 35\%$		

5.4 Parameter setting

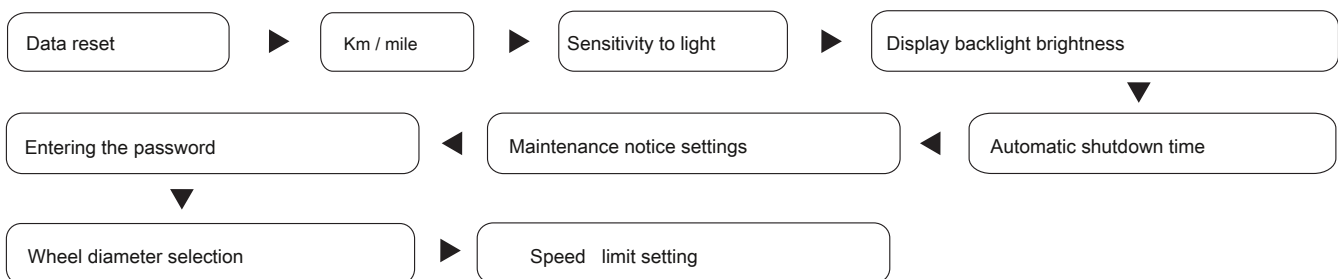
5.4.1 Items to configure:



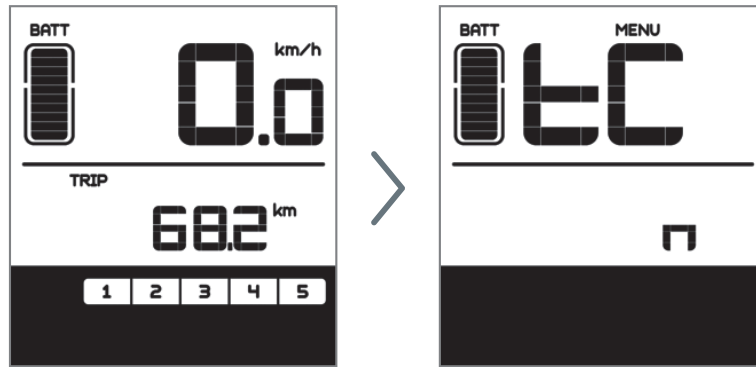

5.4.2 Preparation for adjustment

When the screen is active, press  twice (interval <0.3 seconds). The system will enter the parameter setting of the MENU, where the parameters of the screen can be adjusted. Press to main menu.  twice (interval <0.3 seconds) to return



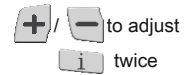

Menu to access parameter settings

In parameter setting, when the parameter you want to set starts flashing, press the parameter value. Press briefly  to switch between the parameters to be adjusted. Press  (interval <0.3 seconds) to leave the submenu.



If no operation is performed for 10 seconds, the screen will return to the normal running screen.

5.4.3 Data reset

Press  twice (interval <0.3 seconds): the screen enters MENU. In the velocity field, tC is displayed. Yes press , and is also displayed. Now all temporary data can be deleted, for example maximum speed (MAXS), Average Speed (AVG), and Single Trip Distance (tRIP). Short press to enter km / mile setting interface.  (<0.3 seconds) for

If the user does not reset the data, the single trip distance and total accumulated walking time will be automatically cleared when the total accumulated walking time exceeds 99 hours 59 minutes.

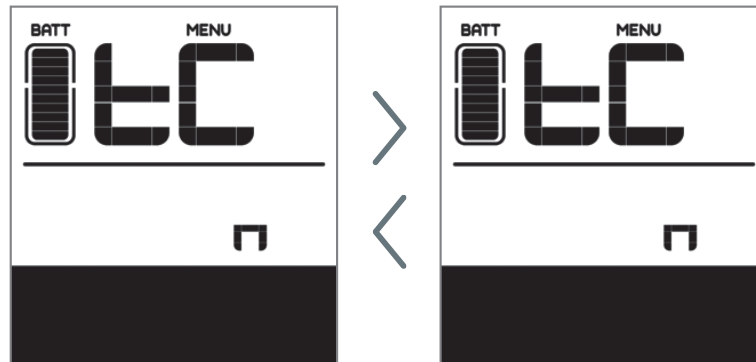



The data will not be erased if the display's light detection function is set to 0 or turned off.

5.4.4 Km / mile

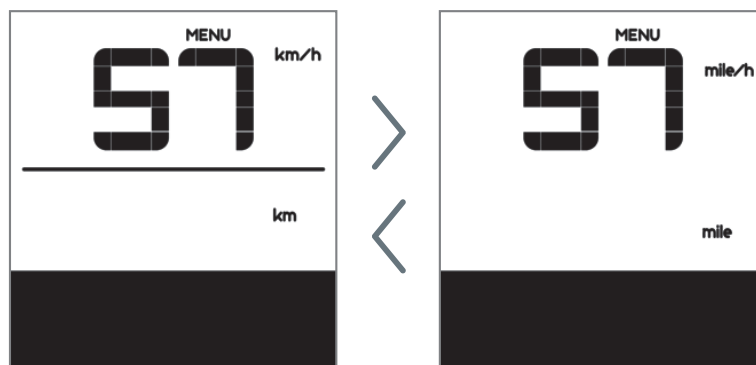
If the speed field shows S7, press  /  to switch between km / h and mph or to set km or miles. press briefly  (<0.3 seconds) to enter the light sensitivity adjustment interface.





5.4.5 Sensitivity to light

If the velocity field shows bL0, use  /  to choose a number between 0 and 5. The higher the number chosen, the greater the sensitivity to light. After this adjustment, short press screen backlight  (<0.3 seconds) to access the interface brightness adjustment.





5.4.6 Brightness of the display backlight

If the velocity field shows bL1, press  / , to choose a number between 1 and 5. The number 1 represents the brightest brightness low and the figure 5 indicates the highest brightness of the display backlight. After this setting, briefly press  (<0.3 seconds) to enter the shutdown time setting interface automatic.



5.4.7 Automatic shutdown time

If the speed field shows OFF, press  / , to choose a number between 1 and 9. The figures indicate the minutes that it will take time for the screen to turn off automatically. After this setting, briefly press  (<0.3 seconds) to enter the maintenance notice setting interface.

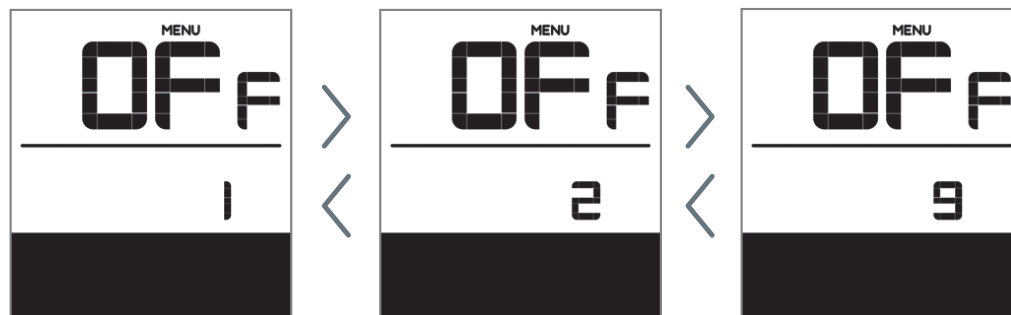

5.4.8 Maintenance notice (can be deactivated)

If the speed field shows nnA, press After this setting,  /  to choose 0 or 1. 0 deactivates the function and 1 activates it. press briefly  (<0.3 seconds) to enter the password input setting interface.

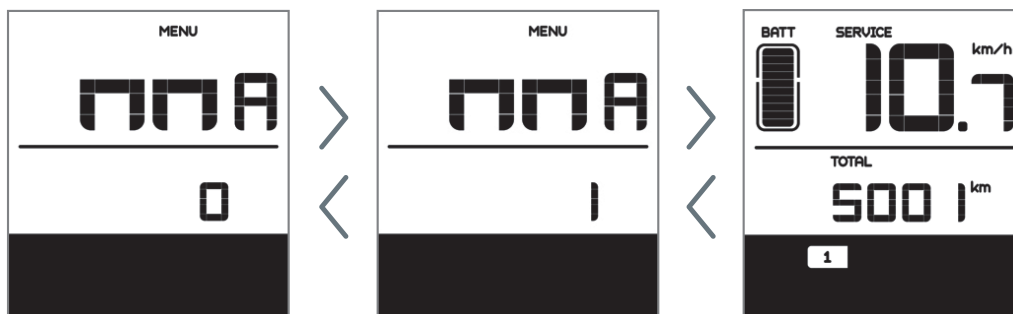

Maintenance notice settings

The display will indicate the immediate need for maintenance, based on information such as accumulated walking distance and battery charge cycles.

- When the total accumulated distance exceeds 5000 km (customizable by the manufacturer), the symbol will appear on the screen.

SERVICE. When the display is turned on, the accumulated distance signal flashes for 4 seconds, indicating maintenance is required.

- When the number of battery charge cycles is greater than 100 (customizable by the manufacturer), the symbol will appear on the screen.

SERVICE. When the display is turned on, the battery symbol flashes for 4 seconds, indicating that maintenance is required.

5.4.9 Battery menu information

Information displayed in speed field b01	Explanation
	actual temperature
b02	maximum temperature
b03	minimum temperature
b04	total voltage
b05	stream
b06	average current
b07	remaining capacity
b08	full capacity
b09	relative state of charge absolute
b10	state of charge charge /
b11	discharge cycle
b12	maximum no-load period period since
b13	last charge voltage cell 1
d01	
d02	voltage cell 1
.....
dn	voltage cell n

5.5 Error code definitions

The MAX-C966 display can show the faults of the electric bike. When a fault is detected, the speed field icon appears, one of the following error codes will appear:



Error code	Description of the error	Error resolution method
«03»	Brake activated	Check if a brake cable is stuck
«04»	Throttle has not returned Throttle fault	Check if the throttle has returned
"05"		Check throttle
«06»	Low voltage protection Over	Check battery voltage
«07»	voltage protection	Check battery voltage
«08»	Motor signal cable fault Motor phase cable	Check motor module
«09»	fault	Check motor module
"11"	Controller temperature sensor failure	Check the regulator
«12»	Current sensor failure Battery temperature	Check the regulator
«13»	failure Speed sensor failure BMS	Check battery
"21"	communication failure Communication	Check the mounting position of the speed sensor
«22»	failure	Replace the battery
«30»		Check the regulator connection

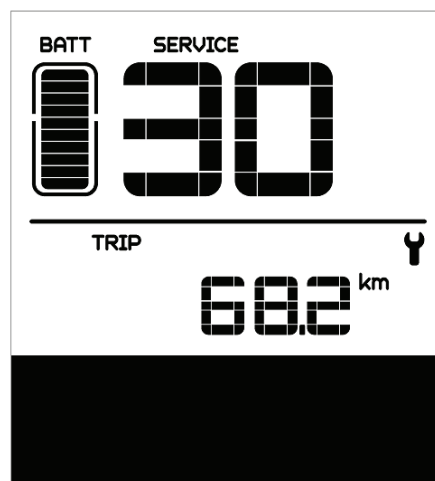

Error display

6. RECOMMENDATIONS AND MAINTENANCE

6.1 General requirements

NCM electric bikes use metal covers to cover electrical components, so we recommend-

We strongly avoid using excessive water to wash the guards and surrounding parts. Use a soft cloth with a neutral solution to wipe dirt off the protectors. Then wipe everything with a clean, soft cloth.

Do not use high pressure air or water hoses to clean; This can force water into electrical components, which can cause a malfunction.

Do not wash the plastic components with excessive water. When the internal electrical parts are affected by water this can corrode the insulator, leading to power-drain problems or other problems.

Do not use soap solutions to wash metal components. Non-neutral solutions can cause discoloration, distortion, scratches, etc.

Avoid leaving the bike outdoors

When not riding, keep the bike in a place where it is protected from snow, rain, sun, etc. Snow and rain can cause the bike to corrode. Ultraviolet rays from the sun can cause unnecessary paint fading or crack any rubber or plastic on the bike.

Recommended torque values

Front wheel nuts Rear wheel nuts Seat tube clamp	22-27 Newton Meters	16.2- 19.8 ft-lb.
Seat tube fixing nut Brake fixing nut	24-29 Newton Meters	17.5-21.3 ft-lb.
	12-17 Newton Meters	8.8-12.5 ft-lb.
	15-19 Newton Meters	11.0- 14.0 ft-lbs.
	7-11 Newton Meters	5.1- 8.1 ft-lb.
Handlebar clamp nut Headphone expander nut	17-19 Newton Meters	12.5- 14.0 ft-lbs.
Cotter pin nuts Brake center bolt	17-19 Newton Meters	12.5- 14.0 ft-lbs.
	9-14 Newton Meters	6.6-10.3 ft-lb.
	2-17 Newton Meters	1.5-12.5 ft-lbs.

6.2 Maintenance schedule

To keep your NCM bike in top condition and to get the most out of your riding experience, we recommend that you follow the suggested maintenance schedule. You should study it and let it become second nature to your driving.

Maintenance program	Each walk	Weekly-mind	Monthly-mind	Every 6 months	Annual-mind
Tire pressure Tire condition	×				
Visual inspection	×				
	×				
Brake lever pressure Quick release	×				
	×				
Handlebar alignment	×				
Saddle alignment	×				
Battery pack locked	×				
Checking the wheel Checking the condition of the frame (includes fissure welds)	×				
Clean and lubricate the chain Check the brake pads Lubricate the forks		×			
Lubricate the brakes and cables Lubricate the folding mechanism			×		
Check all bolts and torque settings Clean bike			×		
			×		
Charge the battery			×		
Check the spokes of the wheels Inspect the condition of the tires			×		
Inspect the saddle, rails and clamp Grease the pedal bearings			×		
Checking the hub bearings				×	
Checking the bearings of the receivers and transmitters				×	
Checking the lower bracket bearings Replace the brake pads				×	
					×
Replace brake cables (depends on use) Replace tires (depends on use)					×
					×

 **WARNING:**

- As with all mechanical components, electrically assisted cycles (EPAC) are subject to wear and high stresses. Different materials and components can react to wear or stress fatigue in different ways. If the design life of a component has been exceeded, it can suddenly fail, possibly causing injury to the driver. Any form of cracks, scratches, or color change in highly stressed areas indicates that the component's life has been reached and should be replaced.

6.3 Troubleshooting

How do I know how much charge my battery has when it is not connected to the bike?

- When you press the battery power button, the LEDs will light up, indicating the remaining capacity.

How can I test the capacity of my battery?

- Contact NCM to arrange to return your battery for testing. If the battery has a capacity greater than 85% during the first year (from the date of purchase), you will be responsible for the return freight. If it is tested and is low capacity within the warranty period, your battery will be replaced.

What happens if my battery dies while using my electric bike?

- Assist will stop when only 1 bar remains on the gauge. Your electric bike can still be ridden without assistance.

Should I always completely drain the battery before recharging?

- There is no need to do a full download every time. We recommend doing a full download every 2-3 months.

What should I do if the rim has a buckle or loose spokes all the time?

- Take your bicycle to a qualified wheel builder or technician for service. The problem can be as simple as adjusting the spoke tension.

My screen lights up, but the motor won't start. What I can do?

- Check the motor plug from the controller. This is a very rigid connection and will not work unless the plug is completely within the gauge line. Handlebar twisting can sometimes cause the plug to pop out slightly if there is not enough clearance in the motor cable.

The screen won't turn on unless the battery charger is plugged in?

- See the error code definition in the display manual and, if necessary, report the error code to NCM.

How is it that competitors' engines produce a different sound?

- NCM uses a different internal structure than some competitors. As a consequence, we have a slightly higher frequency and better torque.

If you have any further questions, please contact us at the following email address:.

6.4 Definition of handling and recommendations

Category 1	Category 2	Category 3	Category 4
Components that only can be replaced after approval of the manufacturer of the bicycle / electronics supplier	Components that only can be replaced after approval of the manufacturer of the bicycle	Components that only can be replaced after approval of the manufacturer of the bicycle or the components	Components that only can be replaced without approval
Motor Sensor Controller Electronic cables Handlebar controls screen Drums Battery charger	Picture Fork (also suspension Zion) Wheel for motor hub Braking system Caliper brake lock Luggage rack Lower clamp	Crank wheel without motor hub Chain or belt (in original width) Hoop tape Rims (original ETRTO only) Mechanical / hydraulic brake cables Brake system (for drum, disc and roll brakes) Handlebar and stem (without alternating with the handlebar and stem) Saddle and seat tube (the maximum variation of the adjustment should not exceed 20mm) Main light	Head receiver and transmitter Pedal (in the same width as the originals) Changes Change system Alternators Internal / external shift cables Chain wheel / belt wheel Pinion or gears (when the gears are the same as the originals) Chain guard Mudguards (for same size as the originals and mounted at a minimum distance of 10 mm from the tire) Ray Pipes Dynamo Headlights / Front reflector Rear light / Reflector rear Wheel Reflector Bracket Handles (only with a screw clamp)

Warning:

Modifications to any part of your bike, such as the fork or frame, can make part or all of the bike unsafe. Improperly installed or modified components can put stress on all parts, greatly increasing their chances of failure. Modifications can also affect the handling of the bicycle, resulting in loss of control, falls, and serious injury. Please do not add, remove or modify parts of your bicycle in any way before consulting with a trained bicycle technician. We recommend that you check with us at NCM before making modifications or adding parts to confirm their safety and compatibility with your bike.

7. TECHNICAL DATA

Component	Paris MAX N8R 20 "36V	Paris MAX N8C 20 "36V
Motor	Bafang, MAX, 36V 250W, 25km / h, Center drive motor	Bafang, MAX, 36V 250W, 25km / h, Center drive motor
Drums	DEHAWK, R4Y-3614G, 36V 14 Ah, 504 Wh Bafang,	DEHAWK, R4Y-3614G, 36 V 14 Ah, 504 Wh Bafang,
screen	MAX, C966	MAX, C966
Front fork	RST, SS-A2, Disc brake	RST, SS-A2, Disc brake
Connecting rod	Bafang, MAX, 44Tx3 / 32 Spline Disc	Bafang, MAX, 44Tx3 / 32 Spline Disc
Brake lever	Tektro, L: CL535F-RS, D: CL530-TS	Tektro, L: CL535F-RS, D: CL530-TS
Brake	F: Tektro Disc Brake, MD-M280, P: Shimano Scooter Brake	Tektro, F: Disc brake, MD-M280, P: 857AL, V-brake + Shimano coaster brake
Changes	Shimano, NEXUS, SG-C6001-8R, 8 speeds with roller brake	Shimano, NEXUS, SG-C6001-8C, 8 speeds with coaster brake
Free wheel	Shimano, 18Tx3 / 32	Shimano, 18Tx3 / 32
Rims	Schwalbe, Big Apple 20 " 2.0	Schwalbe, Big Apple 20 " 2.0
Front light	Spanninga, KENDO, 36 V, 20 Lux	Spanninga, KENDO, 36 V, 20 Lux
Back light	Spanninga, SOLO	Spanninga, SOLO
Maximum load (including driver)	125 kg	125 kg
Maximum speed	25 km / h	25 km / h

In order to satisfy the needs of our customers as much as possible, NCM reserves the right to modify the characteristics of its products at any time, without prior notice. Contact an authorized NCM dealer for assistance.

8. WARRANTY

Your NCM electric bike comes with a limited warranty. Please visit ncmbikes.com or your local NCM distributor for details.

EN15194 CE



NCM Bikes GmbH

Eckenerstraße 3
30179 Hannover
Germany

Tel .: +49 511 - 897 938 22 Fax:

+49 511 - 897 938 29

info@ncmbikes.com

www.ncmbikes.com

HES04