

4. Please charge when only 2 power bars remain lit.
5. Push the button at the top of the battery to show the remaining charge.

If you have any further questions, please feel free to contact us by email at support.au@dehawk.com.

Battery Indicator

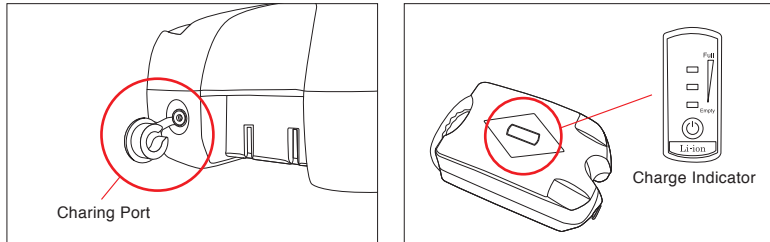

Transport

Please return battery packs that are no longer usable to an authorised bicycle dealer.

The batteries are subject to the Australian Dangerous Goods Code (ADG Code) requirements. Private users can transport undamaged battery packs by road without further requirements.

When being transported by commercial users or third parties (e. g. air transport or forwarding agency), special requirements for packaging and labelling must be observed (e. g. ADR regulations). If necessary, an expert for hazardous materials can be consulted when preparing the item for shipping. Dispatch battery packs only when the housing is undamaged.

Tape or mask open contacts and pack up the battery pack in such a manner that it cannot move around in the packaging. Inform your parcel service that the package contains dangerous goods. Please also be aware of the possibility of more detailed national regulations.

In case of questions concerning the transport of batteries, please refer to an authorised dealer or contact us.

About Us

DeHawk designs and produces battery packs containing top quality, high density lithium-ion cells. We offer multiple down tube-mounted designs as well as rear rack-mounted versions in 24V, 36V, and 48V configurations. Our chargers have several built-in safety features to keep users safe and protect batteries from damage.

Please visit our website www.dehawk.com for more information.

Battery Kit Instruction Manual

- BKS22418 -

- BKS23613 -



Please read before use!

For Your Safety

Thank you for purchasing a DeHawk battery kit. To prevent damage or injury to you or to others, please read the instruction manual before use. Please keep this manual for your future reference.

⚠ WARNING:

- Keep the battery and charger away from water and heat sources.
 - Do not connect positive and negative terminals.
 - Do not short circuit the battery.
 - Keep the battery away from children and pets.
 - Use the charger only for the battery.
 - Do not disassemble the battery or charger.
 - Do not cover the battery or charger, place objects on top of them or rest objects against them.
 - Do not expose the battery and charger to shocks (e.g. by dropping).
 - Stop the charging procedure immediately if you notice anything unusual.
 - In the unlikely event of the battery catching fire, DO NOT attempt to put it out with water. Use sand or another fire retardant instead and call emergency services immediately.
 - Avoid contact with the battery and charger during the charging procedure; the charger heats up considerably.
- ⚠ Please take note of the additional information on the rear of the battery case.
- ⚠ It is important to charge the battery every six months for one to two hours at the minimum. The battery should have at least two LED lights (30%~40% charge) blinking before charging. Failing to maintain the minimum charge level can cause harm to the battery and could result in the warranty of the battery becoming void.

Disposal Instructions

Battery packs, accessories and packaging should be sorted for environmental-friendly recycling. Do not dispose of the battery packs into household waste! Tape or mask off the contact surfaces of the battery pack's terminals with adhesive tape before disposing of battery packs. Do not touch heavily damaged eBike batteries with your bare hands. Electrolyte may escape and cause skin irritation. Store the battery in a safe location outdoors. Cover the pins if necessary and inform your dealer. They will help you to dispose of it properly.



Only for EC countries

According to the European Guideline 2012/19/EU, electrical devices/tools that are no longer usable, and according to the European Guideline 2006/66/EC, defective or used battery packs/batteries, must be collected separately and disposed of in an environmentally correct manner.



Parts Included

1. Battery
2. Mount
3. Keys
4. Charger

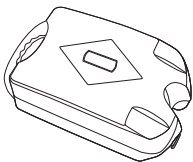

1

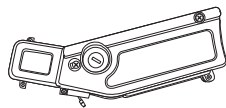

2



3

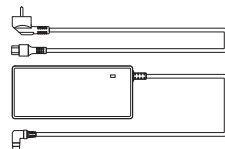

4

Technical Specifications

Nominal Voltage	24V	36V
Max. Charge Voltage	29V	42V
Cut-off Voltage	21V	31V
Capacity	18Ah (432 Wh)	13 Ah (468 Wh)
Max. Rated Current	18A	
Max. Charging Current	3A	
Cell Format	NMC-18650	
Cycle Life	up to 1000 charge/discharge cycles, >60% remaining capacity after 500 cycles	
Storage	-5~-35°C, relative humidity <75%	

Installation and Charging

1. Disassemble the cage of the battery holder. Remove the 8 bolts and separate the cage and holder core.

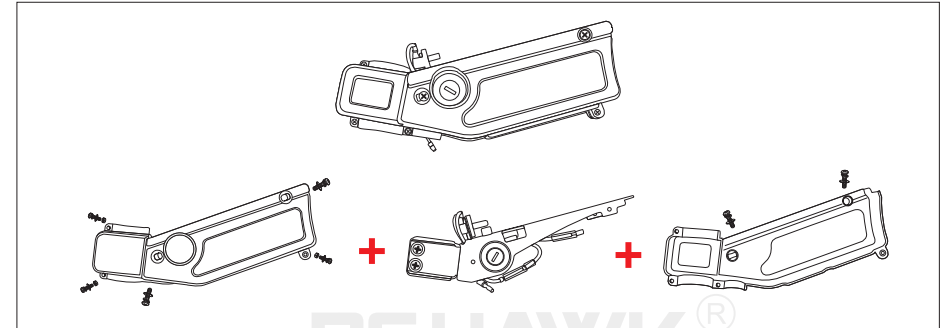

2. Fasten the holder core on the seat tube of the frame set, then assemble the cage on the holder core.

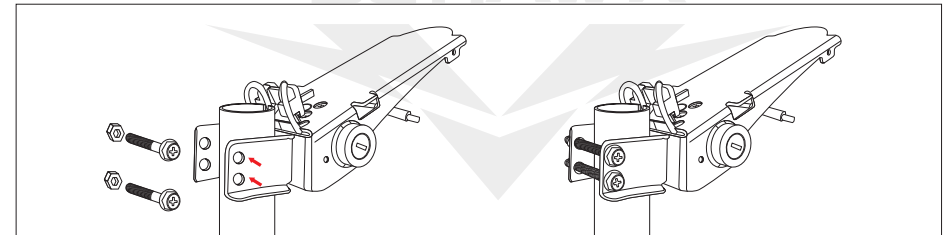

3. Insert the battery into the holder and lock it with the key.

